

## **Application of AE Techniques in Condition Monitoring and Diagnosis of Rotating Machinery**

<sup>1</sup> Mohammed A. A. Elmaleeh<sup>1</sup>, Hassan Y. Ahmed <sup>2</sup>

<sup>1</sup>Email: maleeho@hotmail.com, maleeh\_mowafug@yahoo.com,

<sup>2</sup>Communications & Networking Engineering Department, Computer Science College,  
King Khalid University, Abha, Kingdom of Saudi Arabia.

### **ABSTRACT**

Condition monitoring (CM) is the process of monitoring a parameter of condition in machinery, such that a significant change is indicative of a developing failure. It is of great practical significance in manufacturing industry since it provides updated information regarding machine status on-line. This allows maintenance to be scheduled in order to avoid accidental outages that cause production loss and may lead to catastrophic machine failure. Rotating machines are recognized as the core and fundamental equipment of most engineering systems such as petrochemical plants, automotive industry, power stations, oil refinery, etc. that necessitate precise and ingenious performance. Bearings represent the most important part in rotating machinery. Major problems in the machines are due to bearing faults. It is therefore necessary to monitor and diagnose the bearing operating condition in order to avoid serious problems in the machinery. This paper discusses the concept of acoustic emission (AE) monitoring techniques for detection and diagnosis of bearing deterioration and faults. The acquired AE signals are processed and analyzed using LabVIEW and MATLAB to detect bearing problems at incipient stages.

### **Introduction**

Condition monitoring is the process of monitoring a parameter of condition in machinery, such that a significant change is indicative of a developing failure. It is a

major component of predictive maintenance. The use of conditional monitoring allows maintenance to be scheduled, or other actions to be taken to avoid the consequences of failure, before the failure occurs. It is typically much more cost effective than allowing the machines to fail. Most of the rotating machines is required to operate within specific limits to avoid exceeding the design specifications that harmful the equipment. I.e. the equipment should operate within specific range of speeds notified by the manufacturer in order to maintain the machine performance and to avoid the unexpected machine malfunction. Early detection of machine degradation or impending failure helps to reduce maintenance costs. Changes in a machine's operating characteristics can be seen before significant damage occurs (Rao, 1996; Yardley, 2002; Bently, *et al.*, 2002 ).

### **1. Vibration Monitoring Techniques**

Several condition monitoring techniques are available, but the most commonly used method for rotating machines is the vibration analysis. The level of vibration can be compared with historical baseline values such as former start-ups and shutdowns, and in some cases established standards such as load changes, to assess the severity.

Interpretation of vibration signals is a complicated process that requires advanced techniques. One commonly employed method is to examine the individual frequencies present in the signal. These frequencies correspond to specific mechanical components such as bearing elements or due to a certain malfunctions such as shaft unbalance or misalignment. By analyzing these frequencies and their harmonics, the location and type of the problem can be identified

Vibration signals in the form of frequency and amplitude are generated due to problems occurred in the moving parts and structure of the machinery. Vibration sensors such as accelerometer, displacement, and velocity are quite common. The frequency range of these sensors is 10 KHz (Mobley, 1999).

## **2. AE Techniques**

Defects in bearings generate phenomena such as friction, impact, cavitation, wear and tear. This phenomena occurs due to stress waves generated when there is a rapid release of energy from a localized source within the stressed bearing. The released elastic energy propagates to its surface as elastic waves called acoustic emission. AE frequency range is 100 KHz - 1 MHz. AE sensors are capable for detecting these elastic waves. Therefore machine deterioration and malfunction can be detected using AE at much at early stages compared to vibration (Li, 2000; Holroyd, 2000 and Elforjani, 2008). This study discusses the AE monitoring technique established to acquire acoustic signals at the bearing housing of the experimental test rig. Signals obtained from measurements are processed and analyzed using LabVIEW to get the information regarding the process being monitored.

### **experimental setup**

Schematic diagram of the experimental test rig used for this study is shown in Figure1. It consists of a shaft supported on two bearing assembly. A three phase electrical motor (model A4300) is coupled to the shaft using flexible coupling element. The shaft is driven by the motor. AE sensor (model WB DIFF AE sensor/ 1m integral cable) is mounted on the roller bearing. A thin layer of couplant grease is applied between the sensor face and the bearing housing in order to fill the gaps caused by surface roughness and to eliminate air gap to ensure good acoustic transmission. This type of sensor is used to get high fidelity and frequency analysis of AE signals as well as providing useful information about the bearing condition and for noise discrimination.

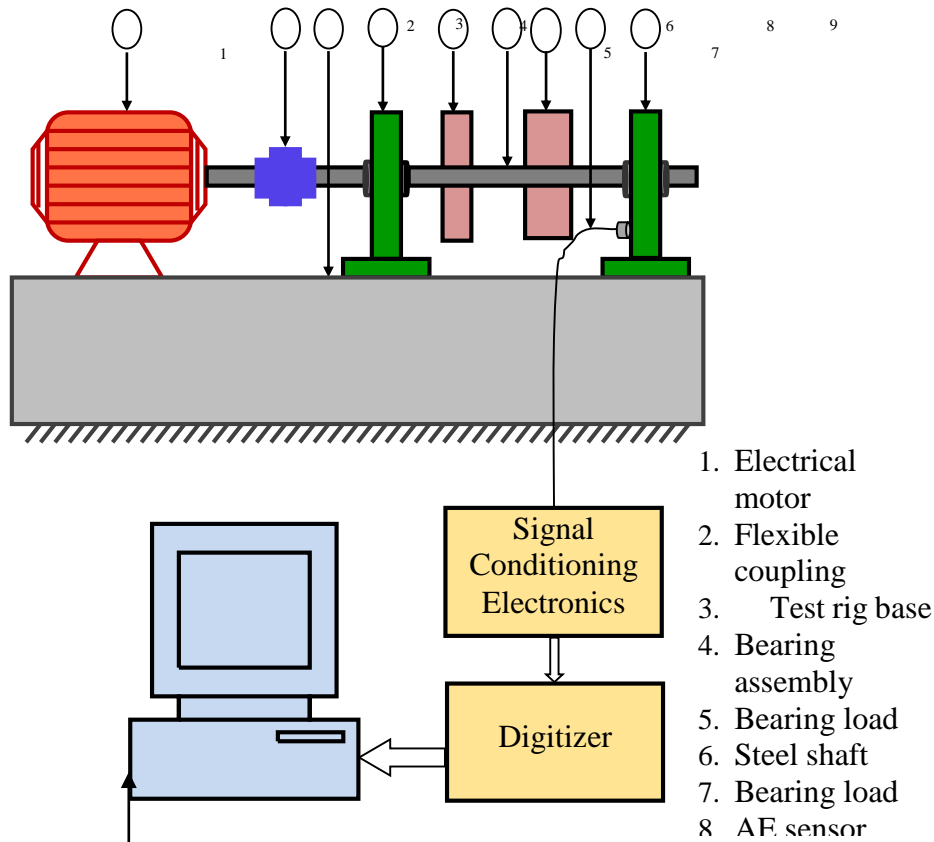
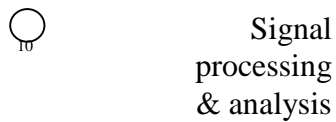

Figure1. Experimental setup



The AE signal is amplified and filtered using 20/40/60 dB, AE PREAMP/ 100-1200 KHz with band pass filter. The PAC AE5A amplifier is a high performance AE system that amplifies and filters an incoming AE signals from the preamplifier. The resulting high-frequency AE analog signal output is connected to TEKTRONIX TDS3012B digital

storage scope in order to view a cause and response relationship. The amplifier AE5A covers the extended AE frequency up to 5 MHz (Li, 2000; Holroyd, 2000 and Elforjani, 2008).

The Tektronix oscilloscope is interfaced to PC using National Instrument general purpose interface bus (NI GPIB 488-2). GPIB is configured using Measurement and Automation Explorer (MAX).

In this paper rolling element bearings from NACHI (6203-2NSE) and KOYO (6203ZZCM FG) manufacturers have been used. Electrical discharge machine is used to create different faults on the bearing assembly.

## **RESULTS AND DISCUSSIONS**

Initially a couple of experiments were conducted for a group of healthy bearings [HB]. Each bearing is mounted on the bearing housing of the test rig and the measurement was repeated for various motor speeds and loads. Consequently, significant amounts of AE data were collected. It is essential in relating any AE activity with bearing faults detection afterwards. The spectral analysis of the acquired signals is obtained using Fast Fourier Transform (Steve Goldman, 1999). Figure 2 is an example of the measurement results.

The second measurements were conducted by removing a part of lubrication grease to realize the onset of bearings failure. To control the amount of grease inside the tested bearing, the bearing was first dismantled from the bearing housing, and then immersed in chemical solution to confiscate all of the grease; after that the bearing was greased with a small amount of lubrication grease and reassembled in the housing and the tests was started identically to previous operating conditions. Several tests were conducted for different amount of grease supplied to bearings. Finally the measurement results were

collected and recorded for comparison studies. Figure 3 symbolizes the AE data acquired.

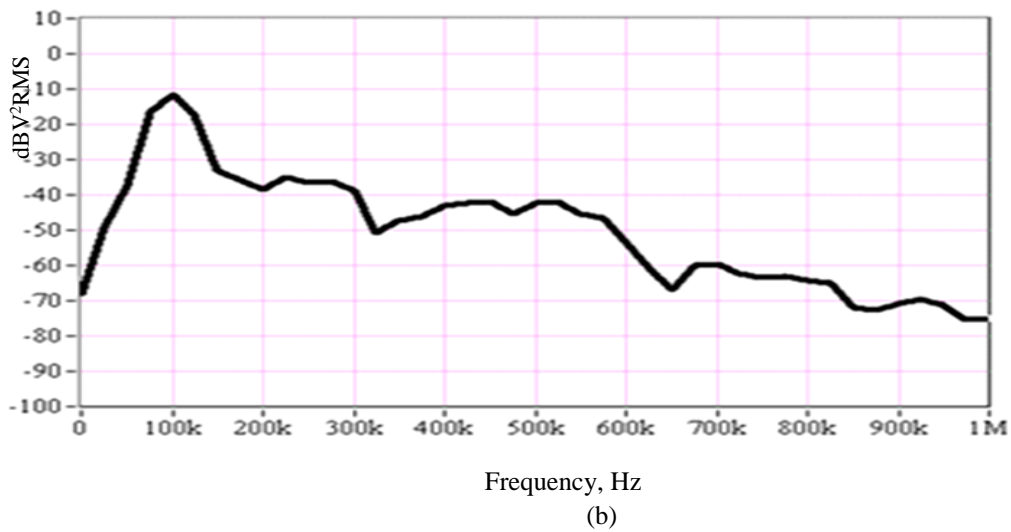
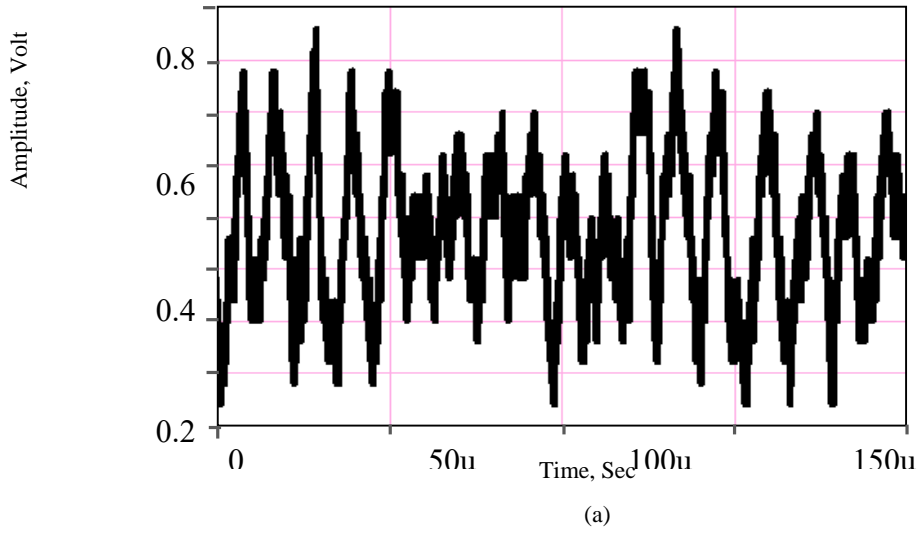

Figure2. AE signal of Healthy Bearing (a) Time domain (b) Frequency Spectrum

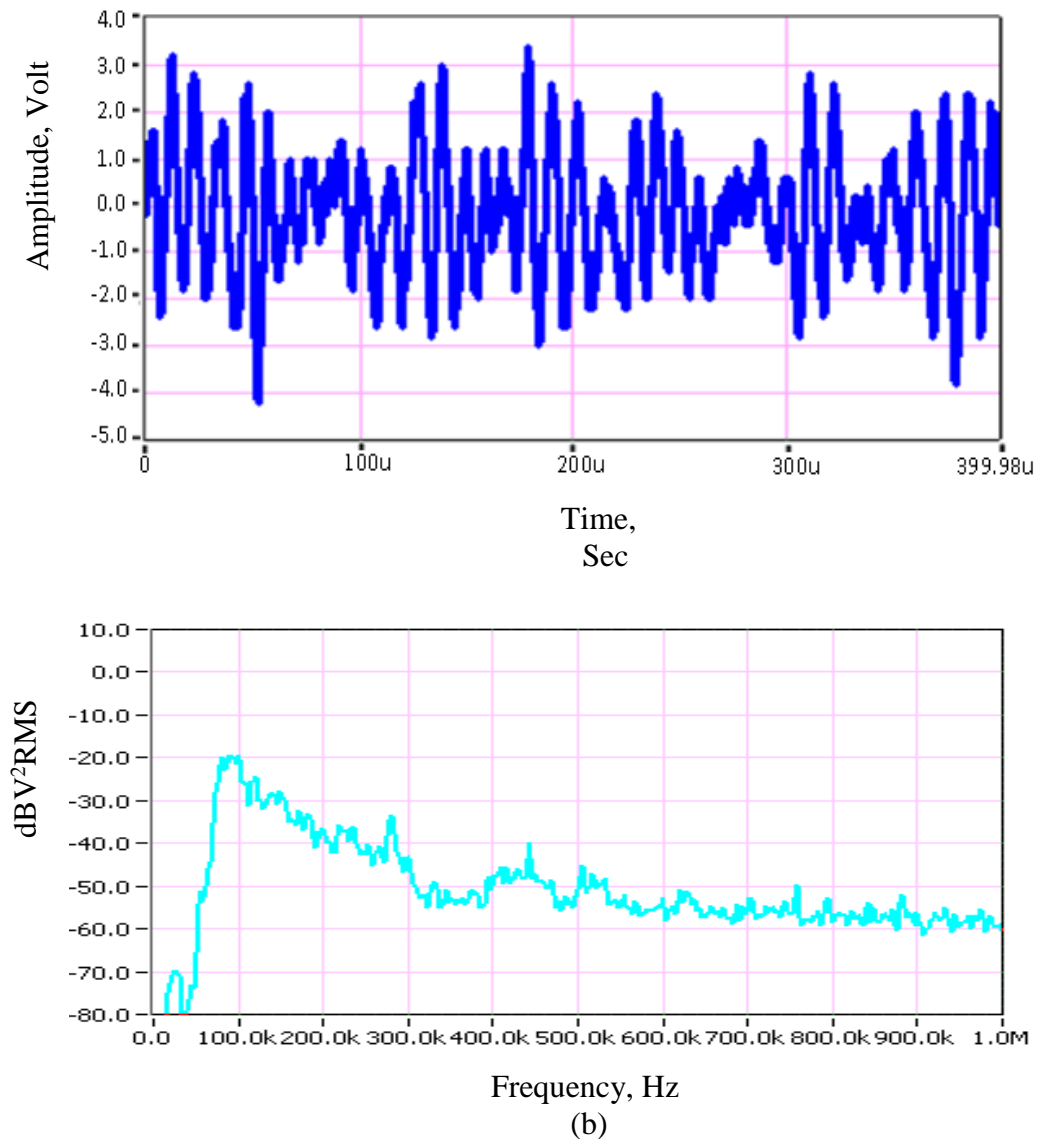

Figure3. AE signal of Poorly Lubricated Bearing (a) Time domain (b) Frequency Spectrum

In evaluating the effect of bearing faults on AE signatures, problems other than poorly lubricated bearings required to be studied. This time EDM machine is requisite to create faults of different sizes in the bearings assembly. In this paper faults of different sizes created on inner and outer race defects were studied. The previous operating conditions were applied on the test rig to capture the AE for bearings with seeded defects. The AE data obtained for outer and inner race defects were presented on Table1.

Table1. AE Data of outer and inner race defect bearings at various operating conditions

Motor speed, rpm	Outer race defect bearing			Inner race defect bearing		
	Vpp, volt	Frequency, kHz	dBV <sup>2</sup> RMS	Vpp, volt	Frequency, kHz	dBV <sup>2</sup> RMS
2000	11.4	100, 160, 420	-50 to -60	10.5	100, 250, 400, 525	-45 to -60
2200	14.3	100, 250	-50 to -60	12.3	100, 400, 525,	-35 to -45
2300	19.4	100, 400, 250	-24 to -35	17	100, 395, 525	-20 to -47
2500	23.2	100, 200	-33 to -40	20.8	100, 250, 395, 525	-15 to -35

To understand the pattern of AE signals for a set of bearings with various defects, several tests were conducted at a motor speed of 2000 rpm, a load of 50 N. SKF bearings were used in the tests. Each test was repeated 40 times. The amplitudes of healthy, poorly lubricated (PLB), inner and outer race defect bearings (IRDB, ORDB) were correlated as shown in Figure4.

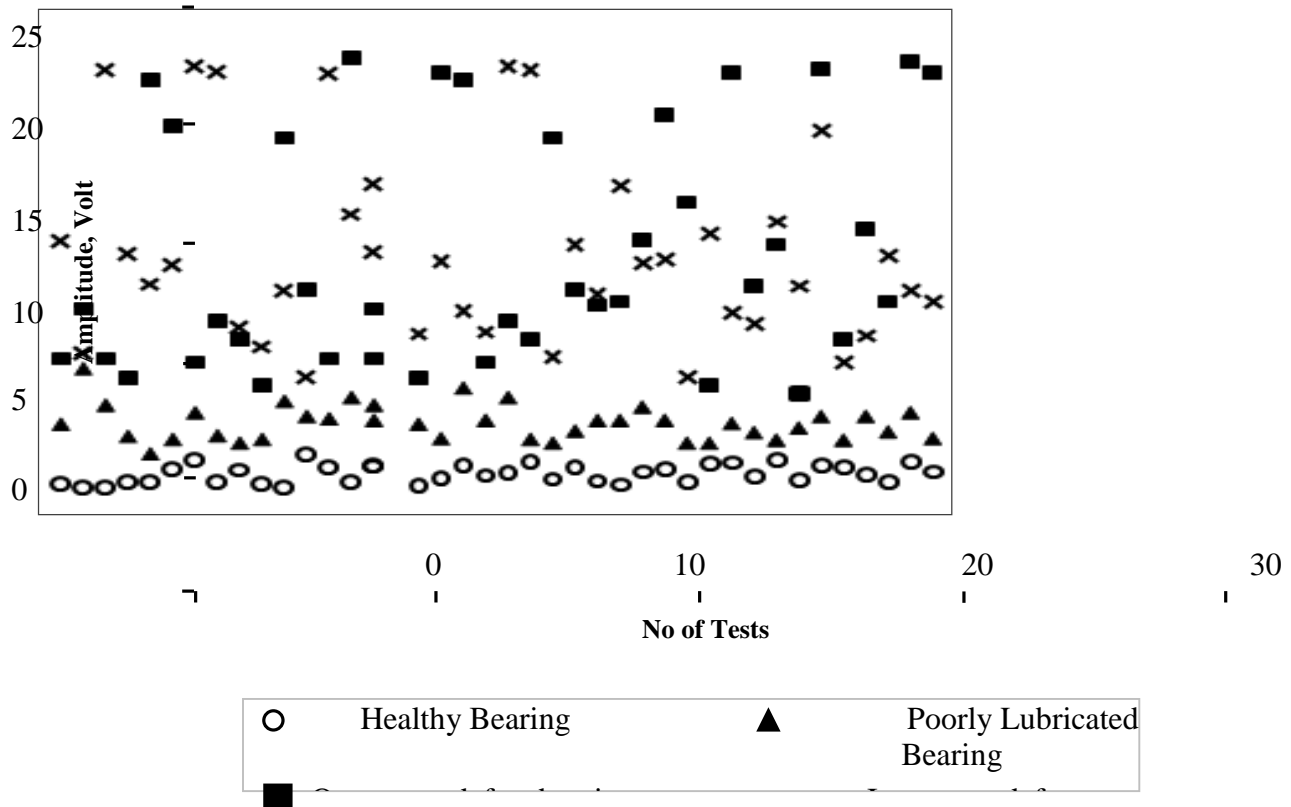

Figure4. Amplitudes of AE signals of Bearings with various health conditions

Under similar operating conditions applied to experimental test rig, it was observed that the amplitudes of healthy bearings do not exceed 3Vpp, that of poorly lubricated are relatively high (reaches 7Vpp). However, the amplitudes of outer race and inner race are quite distinct.

FFT analysis of time domain signals captured from healthy and poorly lubricated bearings shows that no peak signals present for the whole frequency range of the AE sensor. Nevertheless, a peak at 100 KHz persists in all analysis. This peak frequency corresponds to -60 dBV2RMS for most of the measurements conducted. It is noted as the resonant frequency of the sensor.

Unlike healthy and poorly lubricated bearings, spectrum analysis of AE signals obtained in the case of outer and inner race defects confer peaks at frequencies range from 160 to 525 kHz. These frequencies were also observed for bearings with different defect sizes.

Statistical analysis is used to characterize the behavior of bearings under test. In this regards kurtosis (KT), standard deviation (SD), and crest factor (CF) of the time domain AE signals were calculated by LabVIEW. Each test is repeated forty times for the comparison studies. The parameters obtained are shown in Figure5.

From the results shown, the SD of healthy bearings (Fig.5a) do not altered for more than 0.5 for the whole results and kurtosis values never exceed 3, the stipulation that proves the healthy condition of bearing being used (Heng and Nor, 1998; Takeyasau, 2005). SD and KT of poorly lubricated are just larger than that of the healthy bearing. However, for the case of ORDB and INRD these values are comparably high. On the other hand, CF in general does not show significant variation for the various types of bearings. Nevertheless, poorly lubricated bearing indicates the lower values while ORDB and IRDB occupying the higher ranges.

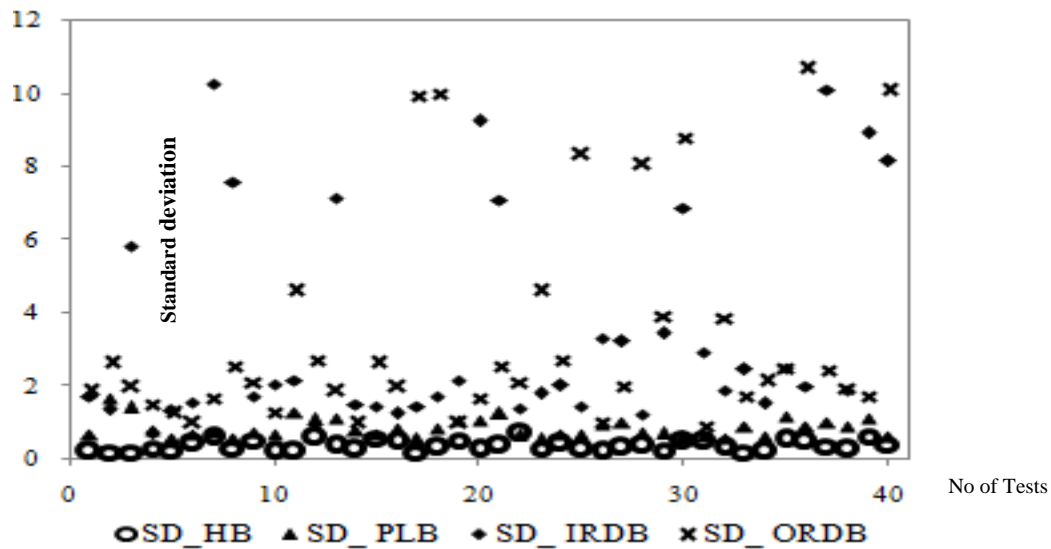

(a)

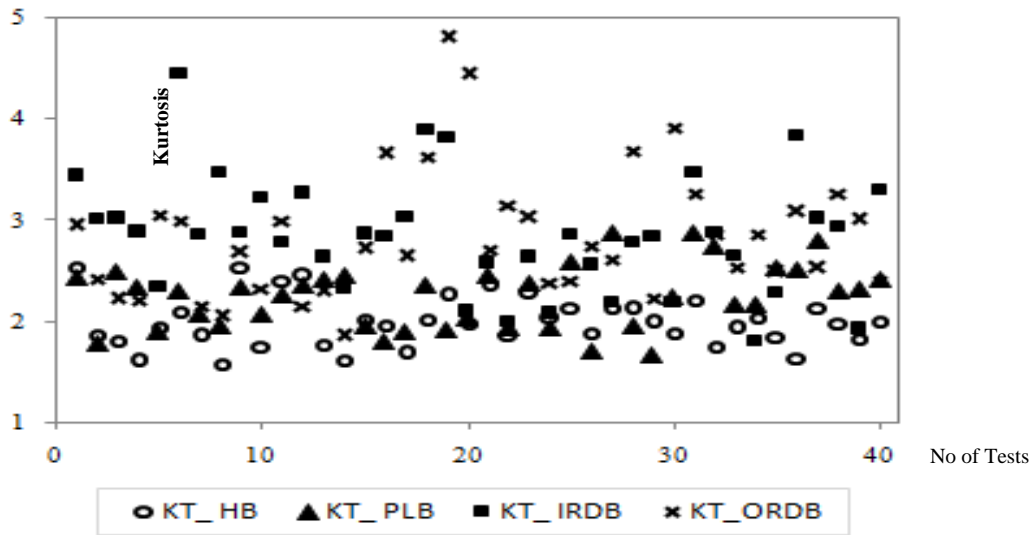

(b)

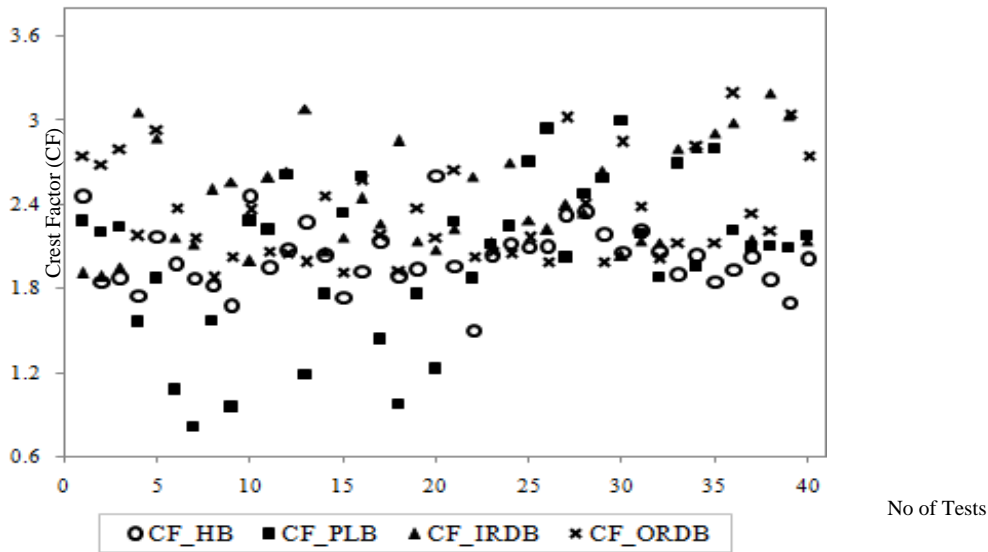

(c)

Figure5 Statistical Parameters of bearings with various faults. (a) SD, (b) KT, (c) KF

### Conclusion

Aberration and imperfections in rotating machinery is a considerable problem in industrial plants and equipment. This complexity is significantly exacerbated by the

occurrence of unplanned downtime of the machinery that causes brutal damage and costly outage. The paper has explained AE condition monitoring technique implement to rotating machinery for early detection of bearings faults. By implementation of the proposed techniques it is expected to obtain valuable information regarding the performance of rotating machinery at incipient stage.

## REFERENCES

- Bently, D. E. C.T. Hatch and B. Grissom** (2002). Fundamentals of rotating machines diagnostics. University of Michigan: Bently pressurized bearing press, ISBN: 9741408106.
- Elforjani , M. A. and D. MBa** (2008). Detecting the onset propagation and location of non artificial defects in a slow rotating thrust bearing with Acoustic Emission, Vol. 50. DOI: 10.1784/Insight.
- Heng, R.B. and M.J. Nor** (1998). Statistical analysis of sound and vibration signals for monitoring of rolling element bearing condition. No.1-3, pp 211-226, s.l.: Applied Acoustics, Vol. 53.
- Holroyd, T.** (2000). Acoustic Emission and Ultrasonic Handbook. s.l.: Cosmoor Publisher Company, ISBN: 19019892018.
- Li, S. Y.** (2000). Acoustic Emission Analysis for bearing Condition Monitoring. Changsha: Changsha Institute of Technology.
- Mobley, R.K.** (1999). Vibration Fundamentals. s.l.: Butterworth Heinemann, ISBN: 97807507671508.
- Rao, B. N. K.** (1996). Handbook of condition monitoring and maintenance management in industry. s.l.: Elsevier advance technology, ISBN: 1856172341.
- Steve Goldman, P.E.** (1999). Vibration Spectrum Analysis. West Nyack: Industrial Press Inc., ISBN: 0-8311-3088-1.

- Takeyasau, K.** (2005). Analysis and behaviour of kurtosis by simplified model of one sided affiliated impact vibration. No.2, pp.192-197, s.l.: Osaka Prefecture University, Japan, IEM Vol4.
- Yardley, E. D.** (2002). Condition Monitoring- Engineering the Practice. London: Institute of Mechanical Engineering, Birdcage.