

EDITORIAL

A new Version of High Stability Output 12-Bit Tracking Analog to Digital Converter

Mohammed A. A. Elmaleeh¹, Hassan Y. Ahmed²

Email: maleeho@hotmail.com, maleeh_mowafug@yahoo.com,

² Communications & Networking Engineering Department, Computer Science College,
King Khalid University, Abha, Kingdom of Saudi Arabia .

Abstract

In this paper a 12-bit tracking analog-to-digital converter (ADC) is designed and its performance is verified. It continuously tests the analog input signal and makes correction when necessary. The resulting digital equivalent of the analog input signal is continuously updated. The least significant bit (LSB) of this converter jumps up and down to track the analog input and this causes the final output to be unstable. To overcome the problem of instability in the digital output the 12-bit tracking ADC is modified by introducing the test bit B0. The test bit is designed to have a voltage equals to that of the LSB. It always sets or resets in tracking the analog value. Using this technique the digital output B1 to B12 of the converter is maintained stable. Test and measurements are performed in the converter circuit to demonstrate the practicality of this version.

INTRODUCTION

ADCs convert continuous physical quantities such as voltage and current, into a digital form. Closed loop ADCs such as successive approximation, dual ramp, etc use different algorithms to perform the conversion. The conversion procedure of these ADCs is periodically repeated from the beginning each time conversion done. i.e. the counter need to reset at the end of each cycle [1, 2]. On the other hand tracking ADC continuously tests the analog input signal and makes correction when necessary in such a way the history of the measurement is taken into account. The conversion is therefore

EDITORIAL

faster. The counter has never to reset. The resulting digital equivalent of the analog input signal is continuously updated. One major problem is that the LSB of this converter is never stable; it always jumps up and down by one bit in tracking the analog value. The digital output permanently oscillates between two subsequent bits B_n and B_{n+1} [1, 2].

In this study continuous oscillation and instability of tracking ADC output is eliminated by introducing the test bit.

1. EXPERIMENTAL Setup

In this paper a 12- bit tracking ADC is designed and tested. The block diagram of the converter is shown in Fig 1. The analog input U_x is compared to U_B . The Up/Down counter output B_0 to B_{11} is converted to current equivalent using digital to analog converter (DAC). The resulting current is converted to voltage (U_B) using an operational amplifier [3, 4].

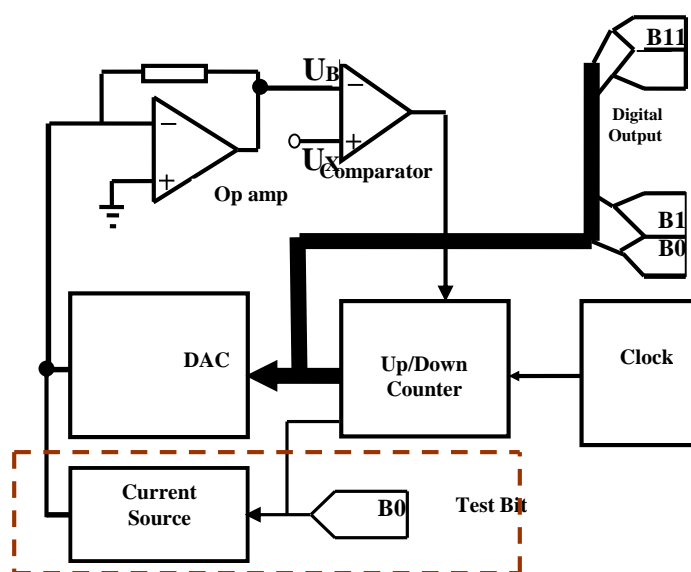

Fig.1. Block diagram of 12-bit tracking

U_x is applied to the non inverting input of the comparator. If U_B is smaller than U_x , then the U/D control input advances the counter to count up. The digital output value B_0 to B_{11} goes higher. This value is converted to its analog equivalent U_B and compared to U_x .

EDITORIAL

Counting up proceeds as long as U_B is smaller than U_X . Finally U_B exceeds U_X . Then the comparator output reverses its state and the bi-directional control input advances the counters to change the counting direction from up to down. The counters output is converted to its analog equivalent U_B and compared with U_X . The following figure shows the counting procedure of the tracking ADC [5, 6].

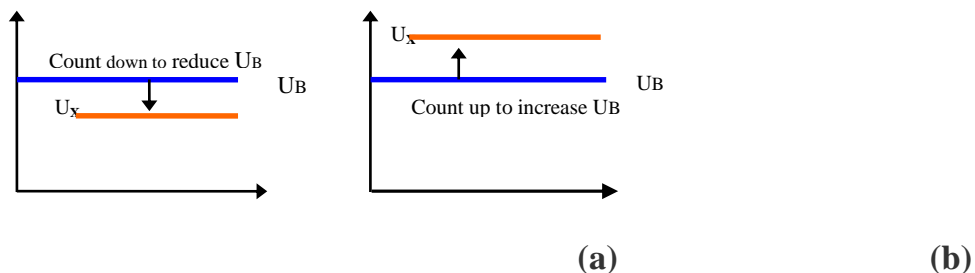

Fig.2. Counting procedure of the tracking ADC. (a) $U_x < U_B$, (b) $U_x > U_B$.

Fig.3 represents the output behavior of the converter when the analog input signal U_x is applied. The LSB to MSB continuously updating until the final result reaches the analog input signal U_x . Then the LSB continuously changes its state in tracking the analog input.

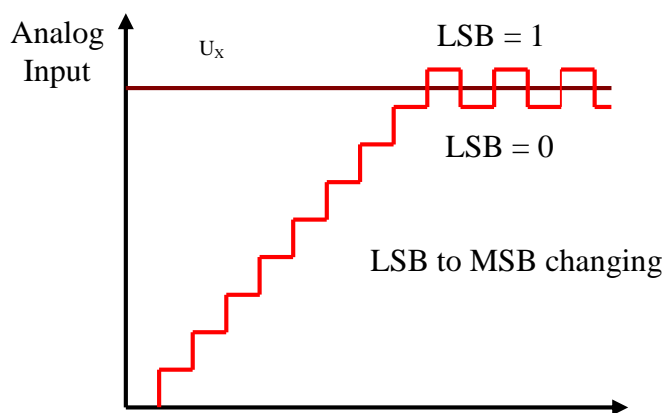

Fig.3. Behavior of LSB in Tracking ADC

2.1 New version of tracking ADC

In this study continuous oscillation and instability of tracking ADC output is eliminated by introducing the test bit. The modified version of tracking ADC is similar to

EDITORIAL

the old type converter with some elements added to its circuitry [note the elements in dotted area of Fig. 1].

Let us suppose that U_B is smaller than U_X . This means that the binary number represented by U_B is too small. It should be increased. In the first step we intend to increase it for 1 only, i.e. from N to $N+1$. However, the value $N+1$ might be too high. In order to avoid wrong decision; B_1 to B_{12} is left unchanged for the time being. The decision to increase the number is checked by setting the test bit B_0 (which brings the same voltage as that of B_1 ; the LSB of the result).

- **Two cases can follow**

[a] If the result of conversion of the increased digital value is still too low then the least bit B_0 is reset and the digital output B_1 to B_{12} is increased for 1 by making on step more in the up direction of bi-directional counter.

[b] If the result is too big then the test bit B_0 is removed and the present digital output remains.

These conditions are achieved if the DAC (AD7541) used in the converter circuit follows the weighting sequence 1, 1, 2, 4, 8,... instead of the usual 1,2,4,8,... sequence. Fig. 4 represents the waveforms of the converter upon applying the input U_X .

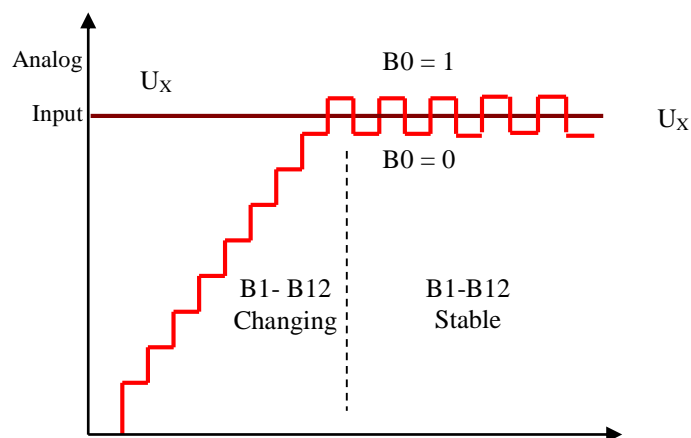

Fig.4. Waveform of Modified Tracking

EDITORIAL

2.2 Stabilizing converter output using the test bit

At the start of conversion, the LSB to MSB are changing because the analog input signal U_x exceeds the initial estimate U_B . At the point where the analog equivalent of the digital result reaches U_x , the test bit B_0 jumps up and down to track U_x while B_1 to B_{12} remain stable.

The test bit behavior is explained with reference to Table 1. The analog value of the test bit is assumed to be 1 V. Let us suppose U_x equals 3.2V and the analog equivalent U_B of the binary number B_1 to B_{12} is zero. Therefore U_B should be increased. The bi-directional counter starts to count up.

. The behavior of the test bit Table 1

Step	U_B (V)	B_3	B_2	B_1	B_0
1	0	0	0	0	0
2	1	0	0	0	1
3	1	0	0	1	0
4	2	0	0	1	1
5	2	0	1	0	0
6	3	0	1	0	1
7	3	0	1	1	0
8	4	0	1	1	↓
9	4	1	0	0	↑
10	5	1	0	0	1

U_B too low, B_0 should set

U_B too high, B_0 should reset

To avoid wrong decision the test bit is set. This is shown in step 2. The corresponding analog equivalent U_B (1V) is too small. In step3 B_0 is reset and B_1 to B_{12} is increased for one step up. In this case U_B becomes 1V. It is too small and should be increased.

EDITORIAL

Following this counting sequence it becomes clear that in step7 U_B equals 3V. It should be increased. In step8 B_0 is set and the corresponding U_B is 4V. i.e. the result is too big therefore B_0 should be removed and the binary number B_1 to B_{12} remains. The test bit B_0 jumps up and down by one bit in tracking the analog input U_x while the binary patterns B_1 to B_{12} are stable.

The test bit B_0 shown in Fig.5 controls the current source. Current source circuit provides the constant current I . This current flows either through the transistor Q_1 when B_0 is higher than U_{REF} or through the transistor Q_2 when B_0 is smaller than U_{REF} . The current I flows through the small value resistor R_1 . The resistor R_2 is much bigger than R_1 and has no influence on the current. The voltage drop U_0 appears at the collector of the transistor Q_1 when it conducts. When the test bit B_0 is set the voltage U_0 should cause the current which equivalent to one bit through R_2 into the summing point at the inverting input of the operational amplifier.

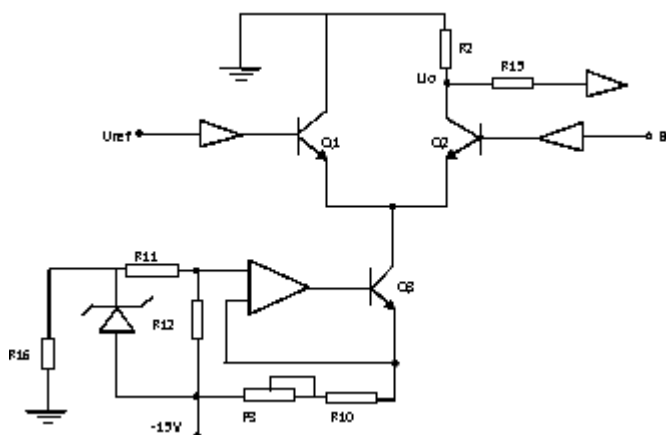

2. MEA: Fig.5. The test bit circuitry

A preliminary test is carried out in the converter circuit. The test bit circuitry is disconnected from the modified 12-bit tracking circuit by removing the elements in dotted area of Fig. 1. The DAC output that ramps up to whatever level the analog input signal is at, output the binary number corresponding to that level, and starts over again.

EDITORIAL

Plotted over time, it looks like the ramp signal shown in Fig.6. This indicates that, the converter circuit functioned properly [7, 8].

A high resolution adjustable voltage source is used for selecting the analog input signal U_x . At the beginning of measurement, U_x is adjusted to its minimum value. The voltage level is slightly increased until the code word at LSB changed. This indicates the transition occurrence between adjacent quantizing intervals.

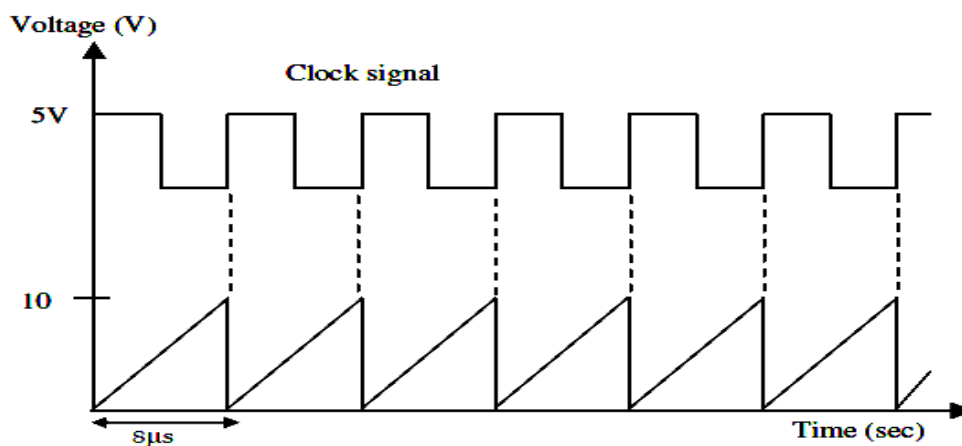

The least significant bit (LSB) jumps as long as U_x changed. The waveforms observed are shown in Fig. 7. Other converter bits follow the same sequence.. This indicates that the circuit truly behaves as the original version of tracking converter.

EDITORIAL

Fig.7. Schematic diagram of A 12-bit modified tracking

Permanent oscillation on the output of the tracking ADC is eliminated by connecting the test bit circuitry (Fig. 1). It adds the current from the current source to the summing point of the operational amplifier. The test bit B_0 jumps permanently when U_x is varied. The LSB to MSB remained stable. Figure 8 represents the LSB behavior of modified tracking converter when U_x varies. The LSB changed its state whenever the analog input U_x crosses the threshold voltage, i.e. from 1 to 0 or vice versa.

The LSB B_1 of the modified converter is used to recover the conversion of the analog input signal U_x to its digital equivalent. This is done by slightly increasing U_x until LSB changes its state. The corresponding digital output B_1 to B_{12} are obtained. The test is repeated for 4096 steps. The transfer characteristic of the converter is obtained by plotting the analog input versus the digital output. Table 1 represents a sample of the data obtained and Fig. 8 shows the corresponding input output relationship.

EDITORIAL

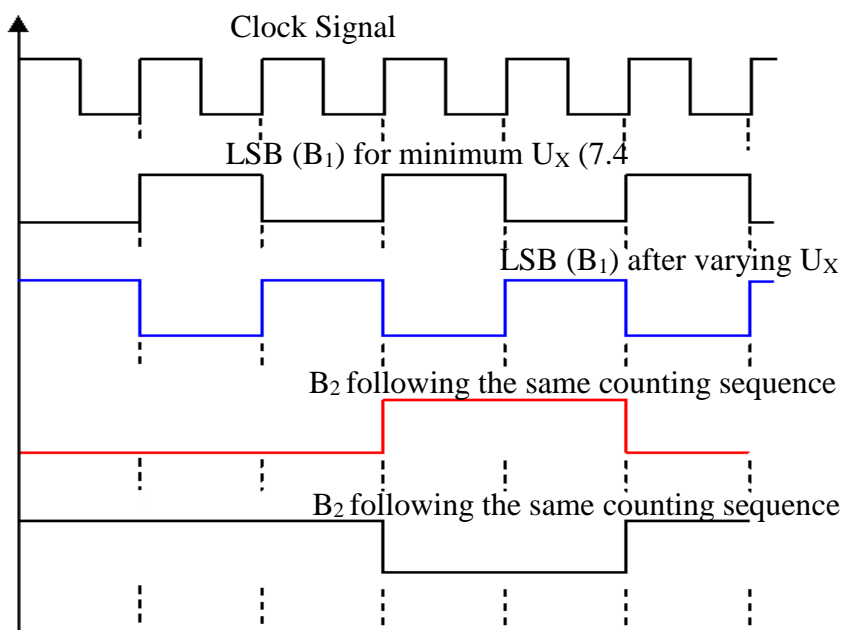
Table1. A sample of analog in U_x versus the binary output

U_x (V)	B1	B2	B3	B4	B5	B6	B7	B8	B9	B10	B11	B12	Decimal Equivalent	Residuals (V)
0.0074	0	1	1	0	0	0	0	0	0	0	0	0	6	-0.0003
0.0154	0	1	0	1	0	1	0	0	0	0	0	0	42	0.0005
0.0988	0	1	0	0	1	0	1	0	0	0	0	0	82	0.0001
0.1975	0	1	1	0	0	0	1	0	1	0	0	0	164	0.0002
0.3911	0	0	1	0	0	1	0	1	0	0	0	0	326	0.0006
0.7810	0	1	0	1	0	0	0	1	0	1	0	0	656	0.0005
1.4785	0	0	0	0	1	0	1	1	0	0	1	0	1232	-0.0004
2.7609	0	0	1	1	1	1	1	1	0	0	0	1	2300	0.0004
3.6003	0	0	0	1	1	1	0	1	1	1	0	1	3000	-0.0002
4.8008	0	0	0	0	0	1	0	1	1	1	1	1	4000	0.0003
4.9081	0	1	0	1	1	1	1	1	1	1	1	1	4090	0.0004

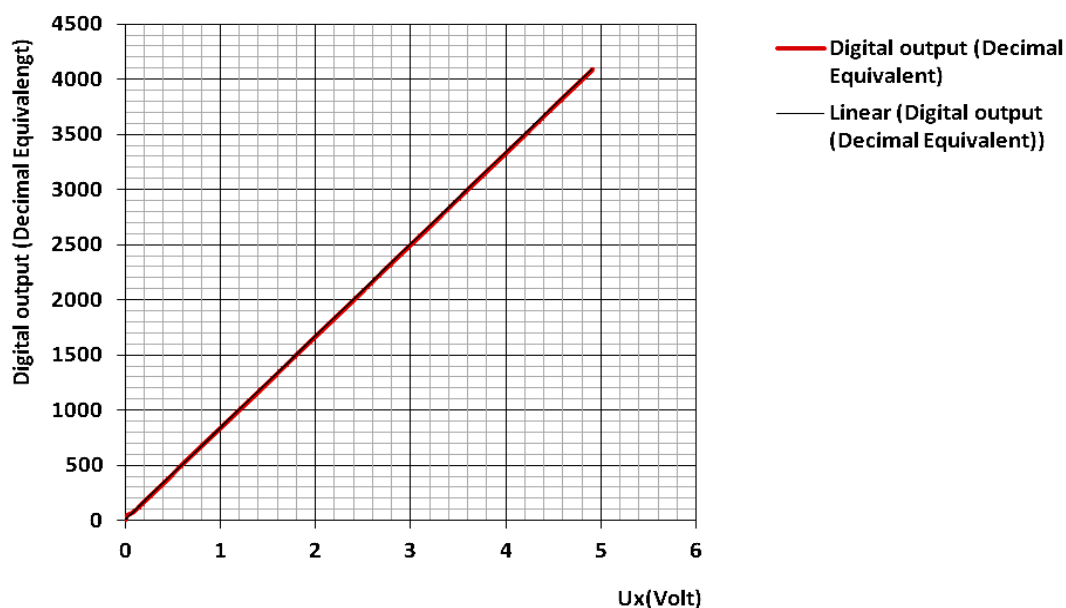
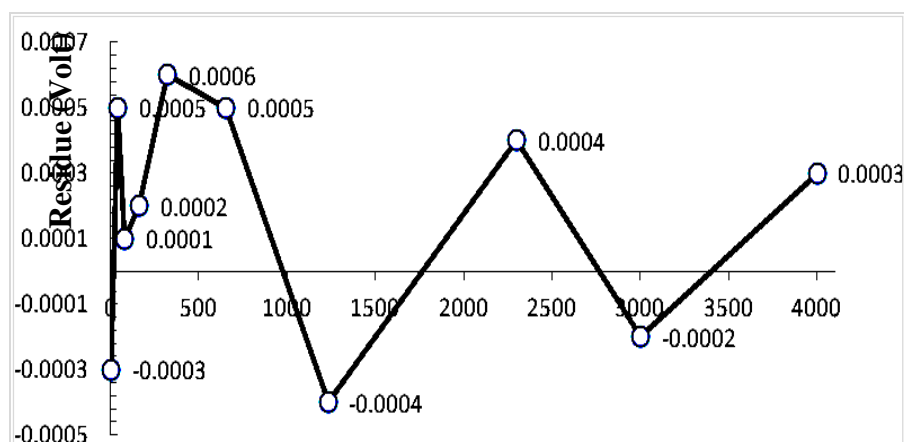

Fig. 8. A Sample result of the input output relationship of the modified converter

The deviation of the measured results from the ideal values represents a straight line. Therefore the residuals are obtained using the best linear fit. The deviations are shown in Table 1 and the relationship between the residue and the binary outputs is shown in Fig. 9.

EDITORIAL

ADC Channels

Fig. 9. A sample plot of residue against the converter output

CONCLUSION

This paper presents the principle of the tracking analog to digital converter. The problem of permanent oscillation in LSB of this converter is solved by introducing the test bit. A modification in the converter circuit is introduced. The DAC output pattern of the new converter circuit is modified to follow the sequence 1, 1, 2, 4, 8,.... instead of the usual sequence 1, 2,4,8,..... .The converter resolution can be enhanced by further use of U/D counters. Converter speed could be improved by using high speed operational amplifiers. The input /output relationships of the converter represent a straight line, therefore the best linear fit is made to determine the deviation of the measured results from the ideal values. One difficulty associated with the qualitative testing of the converter is the large number of samples handled. The input samples required to be converted to digital output ranges from 0 to 2^{12} . The converter has a wide range of measuring frequencies. The optimum measuring frequency is found as 125 k Hz. The conversion time of the modified converter is 16.3 μ Sec which is in good agreement with those cited in the state of art

EDITORIAL

REFERENCES

- N. Balabanian, B. Carlson, Digital logic Design Principles, 2001.
- P. Saul, J. Jenkins, 10-bit Monolithic Tracking ADC. IEEE International, Solid State Conference, Digest of Technical Papers, Volume XXI, 1978.
- L. Thomas, F. Loyel, Digital Fundamentals, 2005.
- Horowitz and Hill. The Art of Electronics, JUL 1999.
- Y. Han and B. Jalali, Continuous Time-Stretched ADC Array Implemented Using Virtual Time Gating. IEEE, Fundamental Theory and Applications, Volume52, Issue 8, AUG 2005.
- S.B. Kaplan, S.V. Rylov, P. D. Bradley, Real Time Digital Error correction for Flash ADC, Application Superconductivity, IEEE Transaction on; Volume 1, Issue 2, Part3, JUN 1997.
- S. Cha and et al, Digitally Controlled Phase Locked Loop with Tracking Analog to Digital Converter, IEEE, Asian Solid - State Circuits Conference, 2005.
- T. H. Tsai, P. J. Hurst, S. H. Lewis, Band Width Mismatch and Its Correction in Time Interleaved ADCs IEEE Circuits and Systems II, Volume3, Issue 10, Oct 2006.

EDITORIAL

المخلص

في هذا البحث تم تصميم دائرة المبدل التماثلي الرقمي التابع ذو البتات الاثنتي عشر للقيام بعملية تبديل الاشارات التماثلية إلى قيم رقمية . ونسبة للذبذبة التي تحت في القيم الرقمية عند أوجه خروج هذا المبدل تمت تعديل دائرته بإضافة دائرة إلكترونية مبسطة . سميت هذه الدائرة بدائرة اختبار البت. تقوم هذه الدائرة بإضافة التيار المناسب إلى التيار المكافئ للقيم الرقمية الناتجة عند أوجه خروج المبدل لجعل قراءتهم في حالة ثبات دائم . أمكن الحصول على التيار المكافئ للقيم للمبدل الرقمي التماثلي و المستفاد منه في عمل التغذية الخلفية.

أجريت عدة تجارب في دائرة المبدل ثم قورنت النتائج مع عدد من المبدلات المتواجدة في الاسواق فكانت متقاربة لنسبة كبيرة. ولقد امتازت دائرة المبدل التماثلي الرقمي التابع عن بقية المبدلات بسرعة التبديل ويرجع ذلك لمتابعة القيم التماثلية المراد تبديلها على الدوام دون الإبتداء من الصفر عند لحظة الإنتهاء من عملية التبديل الأولي كما هو الحال في حالة المبدلات الأخرى .