

EDITORIAL

Thermocouples Technology and Applications A review

Abdalla A. Osman¹ Abdulrasoul J. Alzu baidi² Ali M. Abdelrahman³

¹School of Computer Science and Information Technology, Wad Medani Ahlia College, Medani Sudan.

²Dept. of Electronic Engineering Faculty of Engineering, Sudan University for Science and Technology, Khartoum, Sudan.

³Dept. of Computer Engineering, Faculty of Engineering and Technology, University of Gezira, Medani, Sudan.

ABSTRACT

This paper gives an intensive survey of thermocouples. In particular, it describes the principles of operation and compares between different types of junctions. It provides the major advances in thermocouples in conjunction with hardware and software for PC interfacing. Also it summarizes the main advantages and disadvantages of thermocouples. Finally the paper highlights the important areas of industrial applications.

Keywords: temperature sensors, thermocouple.

INTRODUCTION

Thermocouples are temperature sensors that are widely used in industry and science to measure temperature. The basic idea of a thermocouple is that when two different wires are joined a predictable voltage will be generated that relates the difference in temperature between measuring junction and reference junction (connection to measuring device).

To select an optimum thermocouple type, your selection criteria must be based on application temperature, atmosphere and required length of service, accuracy, and cost. In practice, to reduce the number of errors that can be developed, a proper type of thermocouple or thermocouple extension wire is also required. Due to chemical reaction most thermocouples are designed using a metallic sheath (chemical resistance) and high purity mineral oxide insulation. Mineral oxide coated type thermocouples have high insulation resistances and are suited for most process applications (dataacquisitionweb, 2005). The signals provided by a thermocouple (output voltage) are small and non-linear; you need to have some way to interpret this output. This can be done by building a signal conditioning circuit and data acquisition module plugged into or connected to a PC and read away.

PRINCIPLES OF OPERATION

Thermocouple was discovered accidentally by THOMAS JOHANN SEEBECK in 1821 (Wikipedia, 2007). He experimentally determined that a voltage exists between the two ends of conductor when the conductor's ends are at different temperatures (Dataacquisitionweb, 2005).

1. See beck Phenomena

The voltage difference, dV (emf), produced across the terminals of an open circuit (Fig.1) made up of a pair of dissimilar metals, a and b, whose two junctions are held at different

EDITORIAL

temperatures, is directly proportional to the difference of the hot and cold junction temperatures, $T_h - T_c$, and does not depend in any way on the distribution of temperature along the metals between the junctions (Seebeck,2003). The factor of proportionality, S_{ab} , is called the relative Seebeck coefficient, thermoelectric power, or just thermopower, of the bi-metallic couple. In general this coefficient varies with the level of the temperature at which the temperature difference occurs(Seebeck,2003). If the circuit is closed the current will flow in the metals, which can be detected by:-

- The magnetic field produced around the wires(Seebeck,2003).
 - The joule heating produced by the resistance in the wires (Seebeck, 2003).
 - Closing the circuit with a capacitor or condenser of sufficient capacity to accumulate a measurable charge for the transient current which will flow in this case (Seebeck,2003).
 - A galvanometer or ammeter placed in the circuit to measure the current (Seebeck,2003).
 - Measuring the amount of chemical substance deposited at the positive and/or negative electrodes in an electrochemical cell(Seebeck,2003).
-

EDITORIAL

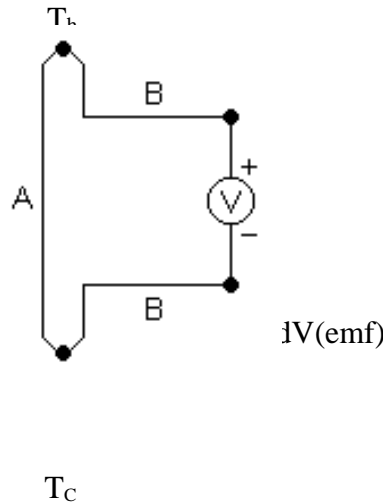

$$dV(\text{emf}) = S_{ab} (T_h - T_c)$$

Fig.1: Thermoelectric effect circuit (Seebeck Effect) (Wikipedia,2007)

The voltage created is on the order of several micro volts per degree as in [2], which can be derived from the following equation.

$$V = \int_{T_c}^{T_h} (S_b(T) - S_a(T)) dT \dots \dots \dots (1)$$

The Seebeck coefficients depends upon conductor absolute temperature, material, and molecular structure hence they are non-linear. For certain temperature measured range, if Seebeck are considerably constant the above equation can approximate as follows.

$$V = (S_b - s_a) \cdot (T_h - T_c) \dots \dots \dots (2)$$

Thus, a thermocouple can be used to measure the absolute temperature by setting one end to a known temperature. The thermopower of the entire thermocouple for small temperature difference can be defined as.

$$S_{ab} = S_b - S_a = \lim_{\Delta T \rightarrow 0} \frac{\Delta V}{\Delta T} \dots \dots \dots (3)$$

Also the above equation can be expressed as a relation between electric field E and Temperature gradient by the following equation.

$$S = \frac{E}{|\nabla T|} \dots \dots \dots (4)$$

2. Reference Junction and Compensation

The thermocouple circuit shown in Fig.2 represents the basis upon which thermocouple standard tables have been established. A new junction is added and held in an ice bath at T_{ice} (0°C). The standards community and thermocouple manufacturers use this topology to develop tables of thermocouple voltage versus temperature (Data acquisition web, 2005).

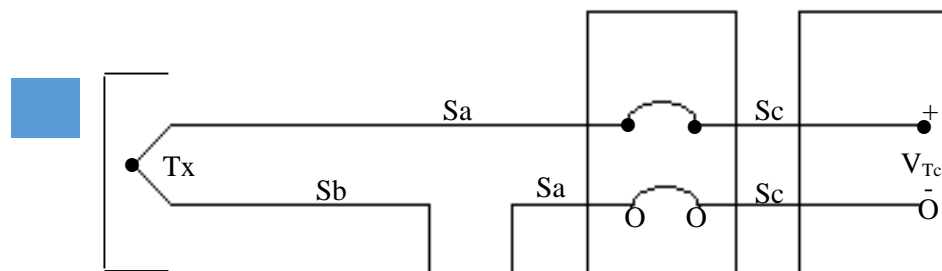

Fig.2: Reference junction and compensation

Fig. 2 Reference junction and compenstion

$$S_a*(T_x-T_c)+S_c*(T_c-T_v)+V_{Tc}+S_c*(T_v-T_c)+S_a*(T_c-T_{ice})+S_b*(T_{ice}-T_x)= 0.....(5)$$

Rearranging and simplifying:

$$S_a*(T_x-T_{ice}) = [V_{Tc}](6)$$

(Values of S_a and S_b determine $[V_{Tc}]$ polarity)

Modern signal conditioning modules use semiconductor electronics, which eliminate clumsy ice-baths by electronically simulating reference junction ice-point temperatures. This process is referred to as Cold-Junction-Compensation, (CJC) or dry reference point (Dataa cquisitionweb, 2005). In addition, these modern signal-conditioning modules provide linear scaled outputs in volts or amperes per degree. Thermocouples require reference junction compensation, to compensate the effect of the reference junction. There are two types of compensations: software compensation and hardware compensation.

2.1 Software Compensation

Software compensation can be achieved directly by measuring the temperature of the isothermal block (the Reference Junction) and using that information to compute the unknown temperature T_x as shown in Fig.3.

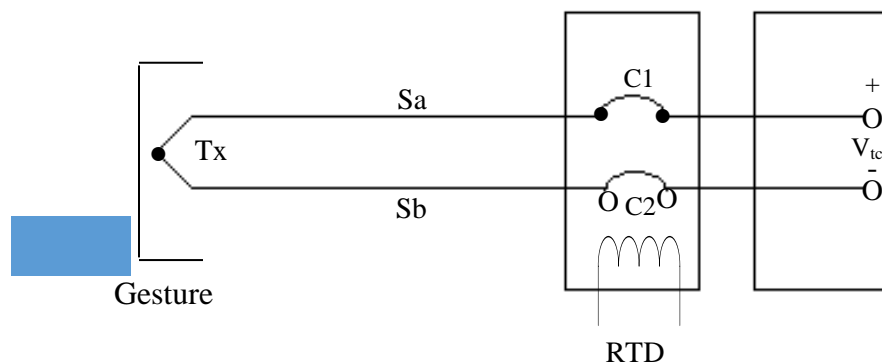

Fig 3:Software compensation

A thermistor, whose resistance R_T is a function of temperature, provides a way to measure the absolute temperature of the reference junction (Dataacquisitionweb,2005). Junctions C1 and C2 and the thermistor are all assumed to be at the same temperature, due to the design of the isothermal block. Using a digital multimeter under computer control, we simply:

1. Measure R_T to find T_{REF} and convert T_{REF} to its equivalent reference junction voltage, V_{REF} , then
2. Measure V_{TC} and add V_{REF} to find V_X , and finally convert V_X to temperature T_X (Dataacquisitionweb,2005).

This method is known as Software Compensation because it depends upon the software of a computer to compensate for the effect of the reference junction. The isothermal terminal block temperature sensor can be any device which has a characteristic proportional to absolute temperature: an RTD, a thermistor, or an integrated circuit sensor (i.e. smart sensor).

2.2. Hardware Compensation

Hardware compensation can be achieved by inserting battery to cancel the offset voltage of the reference junction. Another method is to use ice point reference electronic circuit. The combination of this hardware compensation voltage and the reference junction voltage is equal to that of a 0 °C junction (Dataacquisitionweb,2005). The circuit below shows how to amplify the output signal generated by type J thermocouple and the electronic hardware used for cold junction compensation (reference point). The item AD590 generates current proportion to its temperature and connected to the thermocouple reference point both are at the same temperature. When the current flow from AD590 through the resistors net an electric voltage is generated to compensate changes at thermocouple reference point. According to the above a differential amplifier is used to amplify the thermocouple output. Usually the output signal generated by thermocouple is not linear with temperature. The correction for linearity can be made by using IC's that can cause change in the amplifier gain with respect to the signal value. However, when we use thermocouple with measuring device based on microcomputer, the correction can easily be achieved by a table of correct temperature value stored in ROM. The A/D converts the thermocouple output voltage into a digital value. This value is used as a pointer which points to the location that contains the correct temperature value stored in ROM (Maresh,1998).

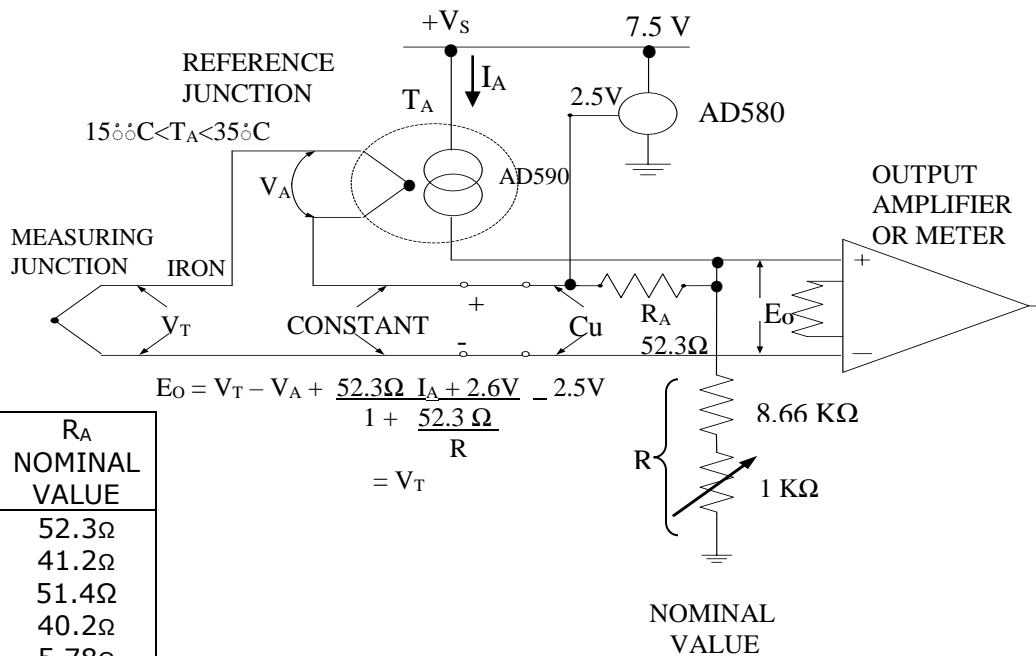

TYP E	R _A NOMINAL VALUE
J.	52.3Ω
K.	41.2Ω
E.	51.4Ω
T.	40.2Ω
S.R	5.78Ω

Fig. 4 Amplifier and cold-junction compensation circuit (Maresh,1998).

2.3. PC Interfacing

In order to improve temperature measurement precision the compensation method must be implemented (as shown in fig.4). Therefore, when the cold-junction is not at 0°C the temperature of this junction must be known in order to determine the actual hot-junction temperature (Maxim, 2007). The output voltage of the thermocouple must also be compensated to account for the voltage created by the nonzero cold-junction temperature. This process is known as a cold-junction compensation. A cold-junction temperature-measurement device must be selected to match the requirements of the system, for instance, ICs such as MAX6610 or LT1025 can be placed as close as possible to the reference junction. As with any temperature-measurement application, accuracy, temperature range, and linearity are all of significant considerations in the selection process. Once a method of cold-junction compensation is established, the compensated output voltage must be translated into a corresponding temperature. A simple "translation" method uses the lookup tables from the NBS (Maxim,2007). Implementing lookup tables in software requires a memory for storage, but the tables can provide quick and accurate solutions when measurements are repeated continuously. Two other methods for translating thermocouple voltages to temperature require somewhat more work than lookup tables: 1) linear approximation using polynomial coefficients; and 2) analog linearization of the thermocouple output signal.

EDITORIAL

analog linearization was commonly used to convert the measured voltage to a temperature (in addition to manually searching through lookup tables) (Maxim,2007). The hardware-based method uses analog circuitry to correct for the nonlinearity in a thermocouple's response. Its accuracy depends on the order of the correction approximation used. This approach is still commonly used in multimeters that accept thermocouple signals(Maxim,2007).

In practice, various applications deploy PCs to interpret thermocouple outputs to useful tasks. Fig.6 shows how to acquire temperature data via PC ports using thermocouple –based sensor. Initially, an analog signal is converted into a digital signal and passed to a PC where, Accompanying program is invoked to write and read the digital signals and hence produces an appropriate action.

EDITORIAL

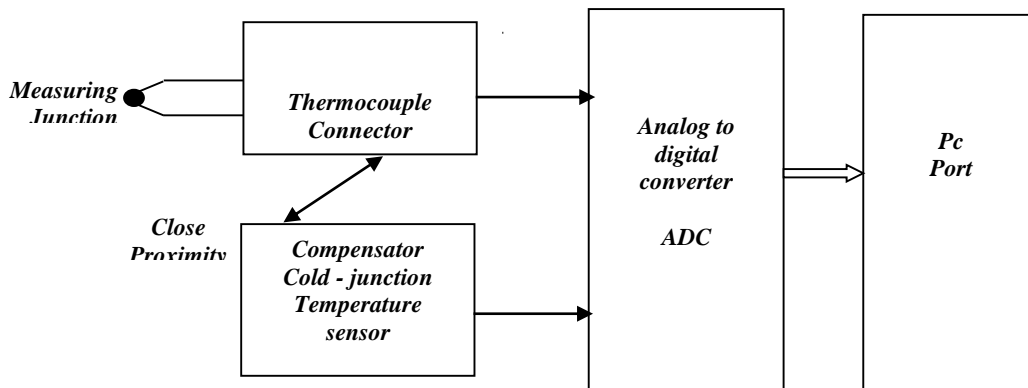

Fig 6: Thermocouple to PC interface

Thermocouple Junction Types

There are three basic forms of sheathed thermocouple junction exposed, grounded, and ungrounded. Thermocouple junction types affect response time, which is defined as the time required by sensor to reach 63.2% of step change in temperature under a specified set of condition(Omega Eng.,2006). Also, the smaller the probe sheath diameter, the faster the response, but the maximum temperature may be lower(Omega Eng.,2006).



Fig.5:The three types of thermocouple junction(Omega Eng.,2006)

Table 1: Comparison between three junction types (Omega Eng.,2006), (ISE,2005),(Savab,2005).

Junction type	Notes on application	Response time
Exposed	Protrudes out of the tip of the sheath and is exposed to the surrounding environment, limited in use to dry, non corrosive, non pressurized applications, best suited for air measurement.	Fastest response time
Grounded	The thermocouple wires are physically attached to the inside of the probe wall. This result in good heat transfer from the outside, through the probe wall to the thermocouple junction. Used for high pressure gas and liquids	Slower than exposed

EDITORIAL

Ungrounded	The thermocouple junction is detached from the probe wall, offers electrical isolation, ideal for conductive solution, or where the measuring instrumentation does not provide channel to channel isolation	Slower than exposed and grounded
------------	---	----------------------------------

1. Thermocouple Selection Criteria

The selection of the optimum thermocouple type is based on the following criteria:

- 1- Metal used in their construction.
- 2- Temperature range(Dataacquisition,2005).
- 3- Accuracy(ISE,2005)
- 4- Abrasion and vibration resistance(Omega Eng.,2006).
- 5- Length of service required (when longer life is required for the higher temperature, the large size wires should be chosen. When sensitivity is the prime concern, the smaller size should be used (ISE,2005)).
- 6- Chemical resistance of the thermocouple or sheath material (Omega Eng.,2006)
- 7- Installation requirements (existing hole may determine probe diameter)(Omega Eng.,2006)
- 8- Thermocouple probe length (effect of conduction of heat from the hole end of the thermocouple, it is suggested that the thermocouple be immersed for a minimum distance equivalent to four times the outside diameter of a protection tube(ISE,2005)). Common sheath materials include Stainless steel and Incoel(Omega Eng.,2006). Iconel support higher temperature ranges than stainless steel; however; stainless steel is often preferred because of its broad chemical compatibility(Omega Eng., 2006).Table 2 shows the comparison between sheath probes.

Table 2: Comparison between sheath probes(Omega Eng.,2006)

Sheath Material	Maximum Temperature	Application Atmosphere			
		Oxidizing	Hydrogen	Vacuum	Inert
304 SS	900°C (1650° F)	Very Good	Good	Very Good	Very Good
Inconel 600	1148°C (2100°F)	Very Good	Good	Very Good	Very Good

ss: stainless steel

2. Measurement and Accuracy

Usually, a thermocouple should be located between work load and the heat source, and approximately 1/3 the distance from the work load to the heat source(ISE,2005).

The accuracy statement can be interpreted as percent of the difference between T_{jct} and T_{ref} (Moffat,1997).

One of the main three factors that affects the value of EMF generated by thermocouple is the materials of the two wires A,B the other two factors are junction temperature (T_{jct}) and reference temperature (T_{ref}).

To solve the problem of measuring the temperature of moving surface, the thermocouple junction can be formed flat (surface probe) and thin to provide maximum contact with a solid surface(Omega Eng.,2006).

For accuracy the major errors arise from the thermocouple materials themselves (Microlink,1996).There are international standards that specify the amount by which sensors

EDITORIAL

may deviate from ideal behavior. There are many types of thermocouple but a small number has distinct calibration tables, color code, and assigned letter designation that are recognized worldwide (Temperature sensors, 2006) (such as American society for testing and materials ASTM). Table 3 shows the comparison between different types of thermocouples. The most common therm-ocouple materials for moderate temperature are Iron-constant, Copper-constant, and Chromel-Alumel (Moffat, 1997).

3 . Advantage of Thermocouple

- 1- Wide temperature range (Dataacquisitionweb, 2005).
- 2- Simple (Savab, 2005).
- 3- Inexpensive (Savab, 2005).
- 4- Rugged (Savab, 2005).
- 5- No external power supply (Savab, 2005).
- 6- Reasonably short response time (Dataacquisitionweb, 2005).
- 7- Reasonably repeatability and accuracy (Dataacquisitionweb, 2005).

4. Disadvantage of Thermocouple

- 1- Non linear output (Savab, 2005).
- 2- Relatively low stability (Savab, 2005).
- 3- Low sensitivity (usually 50 micro volt/ °C) or less (Dataacquis-itionweb, 2005)
- 4- Reference junction (0°C) compensation required (Omega Eng., 2006).
- 5- Accuracy, usually no better than 0.5 °C, may not be high enough for some application (Dataacquisitionweb, 2005).

In spite of these disadvantages still thermocouples are widely used with primary emphasis in the industry. The following section highlights some of the common industrial applications.

EDITORIAL

EDITORIAL

THERMOCOUPLE INDUSTRIAL APPLICATIONS

Thermocouple applications are wide and very useful in industries and science due to its different types of construction metals, probes, and since it consider as a temperature gradient sensor. To maintain proper application you must select the right type of thermocouple for a particular sensing task. The following examples show different thermocouple applications.

1- The temperature on the inside of furnaces and ovens are commonly monitored and controlled by thermocouple inserted into the heated chamber (Nanmac,2005).

2- Measuring the true temperature of the flowing plastic in an extruder nozzle. This provides an accurate temperature profile of the plastic melt, the magnitude and shape of the temperature profile across the stream. The most suitable thermocouple of type J, K, E, and T was designed with low millisecond response time to measure the in-stream temperature (Nanmac,2005).

3- Mold temperature and heat flux measurements during the production of glass containers. Particularly the surface layers of the glass, are cooled while in contact with the forming mold is of great importance in the manufacture of glass containers. The difficulty in measuring the transient temperature changes in the actual forming operations has limited both the understanding and the control of the heat transfer (Nanmac,2005).

Thermocouples of a very fine diameter have been embedded in the glass for measuring the glass temperature. This embedded thermocouples consisted of an oxide insulated ungrounded metallic sheathed thermocouple (Nanmac,2005).

CONCLUSIONS

Thermocouple is a widely used temperature sensor in the field of industries and science because it is simple, inexpensive, and no need for external power supply. Thermocouples measure the temperature difference between the junction end and the open end; they don't measure the individual temperature at a junction. To select an optimum thermocouple you must first specify the main factors such as temperature range, accuracy, thermocouple sheath material, probe length, and the length of service.

It is found that the non-linear output signals generated by thermocouples widely vary from -9.88 to 76.373 mV. Modern trend is to use dry reference point, amplify and condition (linearization circuit) this output signal just enough to convert it to a digital signal in order to simplify the data acquisition systems and automatic control processes. The response time depends upon the thermocouple thermal sensitivity of the thermocouple materials and the junction type (Musa,1999). The exposed thermocouple junction type gives the best result.

One particular advantage of thermocouples is that the sensing elements themselves are very small, allowing thermocouples to be inserted into very small spaces and to respond to rapidly changing temperatures (Sinclair, 2001). The electrical nature of the process means that the circuitry for reading the thermocouple output can be remote from the sensor itself (Sinclair,2001). Note that temperature differences along circuit boards can also give rise to voltages that are comparable with the output from thermocouples. The construction of amplifiers for thermocouple is therefore important and some form of zero setting is needed (Sinclair,2001).

REFERENCES

Data acquisition web (2005). Thermocouples.

URL:<http://www.dataacquisitionweb.com/sensors/thermocouple>.

EDITORIAL

- ISE (2005). thermocouple technical reference data. URL:
<http://www.instserv.com/rmocoupl.htm>.
- Maresh S. (1998). Microprocessors, Programming, Interfacing And Hardware. Ray.
- Maxim(2007).Implementingcold_junctioncompensationinthermocouple applications.
URL:<http://www.maxim-ic.com/an4026>.
- Microlink(1996). Technical notes: Thermocouple accuracy.
URL:<http://www.microlink.co.uk/tctable.html>.
- Moffat Robert J. (1997). Electronic cooling, notes on using thermocouples.
URL:<http://www.electronics-cooling.com/articles/1997/Jan97-1.php>.
- Musa H. (1999). Sensors (part II). Ray.
- Nanmac (2005).Foremost temperature measurement.URI:
http://www.nanmac.com/documents/furnaces-ovens_9_24.pdf.
- Omega eng. (2006). Thermocouples an introduction. URL:
<http://www.omega.com/thermocouples.html>.
- SavabAlena(2005).Thermistors,RTD.&thermocouples.Sensors Scientific Inc.
URL:http://www.sensorsci.com/thermistors_rtd_thermocouples.htm.
- Seebeck (2003).Thomas Johann Seebeck.
URL:<http://www.cthem.ch.huji.ac.il/~eugeniik/history/seebeck.html>.
- Sinclair Ian R. (2001).Sensors and Transducers. Butterworth- Heinemann.
- Temperaturesensors(2006).Thermocouple types. URL
:<http://www.tempsensor.com/tctypes.html>.
- Wekipedia (2007).Thermoelectric effect. URL
:<http://www.answer/topic/thermoelctric.effect>.